



Premium Range

BRIGHT

Experience the European difference

BP889N

Fully Automatic tyre changer



012 664 3556

071 464 0250

sales@integratedmarketing.co.za

Model: BP889N

Product: Fully automatic tyre changer

Description: The BP889N Tyre Changer from Bright is a high-performance, fully automatic machine designed for efficient and precise tyre mounting and demounting. Equipped with a pneumatic tilting arm, a robust turntable, and a powerful bead breaker, the BP889N is ideal for handling a wide range of tyres, including low-profile and run-flat types. Its durable construction and user-friendly controls ensure reliability and ease of use in busy workshops, making it a versatile choice for both standard and specialty tyre services. Designed and Engineered in Europe.

| Features: | Benefits: |
|---|---|
| Designed and Engineered in Europe | Italian made |
| Fully Automatic Operation | The BP889N is designed for ease of use with automatic functions that streamline the tyre mounting and demounting process, improving efficiency. |
| Pneumatic Tilting Arm | The machine's pneumatic tilting arm allows for quick and smooth positioning, accommodating different tyre sizes and reducing operator effort. |
| Manual Bead Breaker | A bead breaker is used to "break" or loosen the tyre's bead (the part of the tire that seals onto the wheel) from the rim. Precision control over the pressure applied to the tire, which reduces the risk of rim damage and increases reliability. |
| Robust Turntable | The heavy-duty turntable ensures a secure grip on the tyre, with jaws that adjust to different rim sizes. This offers stability and precision during operation. |
| Precision Inflation System | The tyre changer comes with a built-in inflation system that allows precise control over tyre pressure, ensuring safe and consistent inflation. |
| Run-Flat and Low-Profile Tyre Compatibility | Specifically designed to handle challenging tyres, including run-flat and low-profile models, providing versatility for various tyre services. |
| Ergonomic Design | The machine's user-friendly design includes conveniently placed pedals and controls, reducing operator fatigue and increasing workflow speed |
| Durable Construction | The BP889N is built from high-quality materials, ensuring long-lasting durability and reliability in a high-volume workshop environment. |
| | Increased Efficiency: The automatic features and pneumatic arm improve the speed and accuracy of tyre changing, boosting productivity in the workshop. |
| | Reduced Operator Fatigue: The ergonomic design and automation features reduce manual effort, helping operators perform tasks with less physical strain. |

| | |
|--------------------|---|
| | Versatility: Capable of handling a wide range of tyres, from standard to high-performance types, including run-flat and low-profile tyres, making it a versatile tool for workshops. |
| | Enhanced Safety: The powerful bead breaker and precision inflation system enhance safety, preventing damage to tyres and rims while ensuring proper inflation. |
| | Durable and Long-Lasting: The high-quality materials and robust construction provide a long operational life, reducing maintenance costs and downtime. |
| | Better Customer Service: Faster, more reliable tyre changes improve customer satisfaction, helping workshops manage higher volumes with confidence. |
| Training available | Technicians can be professionally trained to use the machine and get the maximum benefit from it. |
| 1 year warranty | The machine will be repaired if there are any factory faults and can be replaced if required. |
| Spares available | Should you have a breakdown you will not have to wait for your machine to be repaired. If there is anything we don't have, we fly it in directly from the Suppliers. |

| Technical information | |
|-----------------------|-------------------|
| Outside clamping | 11" - 24" |
| Inside clamping | 13" - 26" |
| Rim width | 3" - 14" |
| Max wheel diameter | 1100 mm |
| Working pressure | 8 - 10 bar |
| Bead breaking force | 2800 kg |
| Power supply | 220V |
| Motor power | 0.75Kw / 1.1Ke |
| Rotation per minute | 6.5/13 rpm |
| Noise | <70 dB |
| Machine dimensions | 1900*1400*2000 mm |
| Packaging dimensions | 1150*920*1000 mm |
| Net weight | 290 kg |
| Gross weight | 320 kg |

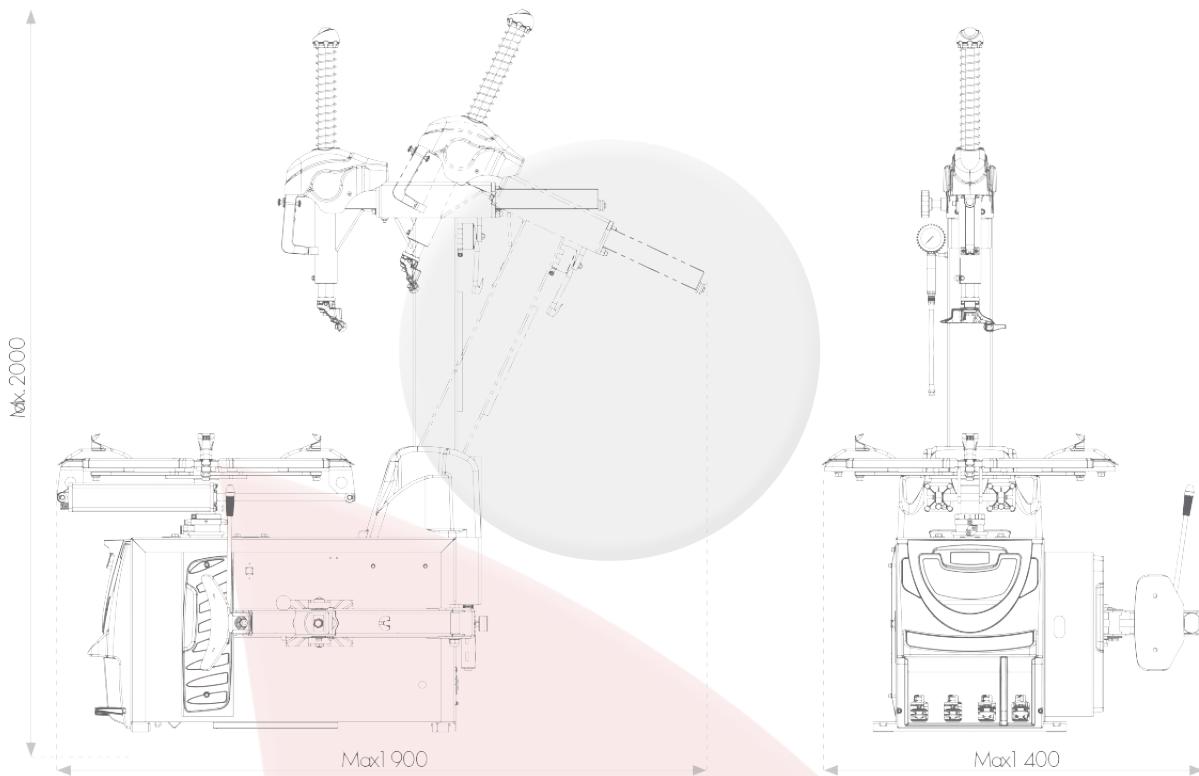

Optional extras

Assist helper arm AL390

